 Details described or illustrated in this booklet may differ from the vehicle's actual specification as purchased, the accessories fitted or the national-market specification. No claims will be asserted as a result of such discrepancies.
Dimensions, weights, fuel consumption and performance data are quoted to the customary tolerances.
The right to modify designs, equipment and accessories is reserved. Errors and omissions excepted.



Benelli

TNT 135

November 2017

INTRODUCTION

Welcome to the world of motorcycling!

As the owner, you are benefiting from the vast experience and newest technology regarding the design and manufacture of high-quality products, which have earned us a reputation for dependability.

Please take the time to read this manual thoroughly, so as to enjoy all advantages of your vehicle. The Owner's Manual does not only instruct you in how to operate, inspect and maintain your vehicle, but also how to safeguard yourself and others from trouble and injury.

In addition, the many tips given in this manual will help keep your vehicle in the best possible condition. If you have any further questions, do not hesitate to contact your dealer.

Our team wishes you many safe and pleasant rides. So, remember to put safety first!

Our company continually seeks advancements in product design and quality. Therefore, while this manual contains the most current product information available at the time of printing, there may be minor discrepancies between your vehicle and this manual. If there is any question concerning this manual, please consult your dealer.

WARNING

Please read this manual carefully and completely before operating this vehicle.

IMPORTANT MANUAL INFORMATION

These are the safety alert symbols. They are used to alert you to potential personal injury hazards. Obey all safety messages that follow these symbols to avoid possible injury or death.

WARNING

indicates a hazardous situation which, if not avoided, could result in death or serious injury.

NOTICE

indicates special precautions that must be taken to avoid damage to the vehicle or other property.

TIP

provides key information to make procedures easier or clearer.

INTRODUCTION	1	• Engine break-in	15
Safety information	3	• Parking	16
• Safe-riding	3	PERIODIC MAINTENANCE AND ADJUSTMENT	16
• Further safe-riding tips	5	• Periodic maintenance chart	17
DESCRIPTION	6	• Checking the spark plug	19
• Left view	6	• Engine oil	19
• Right view	6	• Idle speed	21
• Controls and instruments	7	• Valve clearance	21
CONSUMER INFORMATION		• Air filter	21
• VIN and engine serial number	7	• Checking the throttle cable free play	22
INSTRUMENTS AND CONTROL FUNCTIONS	7	• Checking the clutch free play	22
• Main switch/steering lock	7	• Checking the front brake lever and rear brake pedal free play	22
• Meter & Indicator	8	• Check the drum limit	23
• Handlebar	9	• Checking the brake pads	23
• Fuel Tank Switch & Fuel Tank	10	• Brake fluid	23
• Rear shock absorber	11	• Checking the battery	24
• Rear brake pedal	12	• Replacing the fuses and bulbs	25
• Shift lever	12	TIRE	25
PRE-OPERATION CHECKS	13	STORAGE	26
OPERATION AND IMPORTANT RIDING POINTS	14	• Storage	26
• Starting the engine	14	SPECIFICATIONS	
• Acceleration and deceleration	15	• Specification	27
• Braking	15	• Emission Control System Warranty	29

SAFETY INFORMATION

Be a Responsible Owner

As the vehicle's owner, you are responsible for the safe and proper operation of your vehicle.

The safe use and operation are dependent upon the use of proper riding techniques as well as the expertise of the operator. Every operator should know the following requirements before riding this vehicle.

He or she should:

- Obtain thorough instructions from a competent source on all aspects of vehicle operation.
- Observe the warnings and maintenance requirements in this Owner's Manual.
- Obtain qualified training in safe and proper riding techniques.
- Obtain professional technical service as indicated in this Owner's Manual and/or when made necessary by mechanical conditions.

Safe Riding

Perform the pre-operation checks each time you use the vehicle to make sure it is in safe operating condition. Failure to inspect or maintain the vehicle properly increases the possibility of an accident or equipment damage. See the list of pre-operation checks.

- This vehicle is designed to carry the operator and a passenger.
- The failure of motorists to detect and recognize vehicles in traffic is the predominating cause of automobile/vehicle accidents. Many accidents have been caused by an automobile driver who did not see the vehicle. Making yourself prominent appears to be very effective in reducing the chance of this type of accident. Therefore:
 - Wear a brightly colored jacket.
 - Use extra caution when you are approaching and passing through intersections, since intersections are the most likely places for vehicle accidents to occur.
 - Ride where other motorists can see you. Avoid riding in another motorist's blind spot.
 - Many accidents involve inexperienced operators. In fact, many operators who have been involved in accidents do not even have a current driver's license.
 - Make sure that you are qualified and that you only lend your vehicle to other qualified operators.
 - Know your skills and limits. Staying within your limits may help you to avoid an accident.
 - We recommend that you practice riding your vehicle where there is no traffic until you have become

thoroughly familiar with the vehicle and all of its controls.

- Many accidents have been caused by error of the vehicle operator. A typical error made by the operator is veering wide on a turn due to excessive speed or under-cornering (insufficient lean angle for the speed).
- Always obey the speed limit and never travel faster than the legal speed limit.
- Always signal before turning or changing lanes. Make sure that other motorists can see you.
- The posture of the operator and passenger is important for proper control.
- The operator should keep both hands on the handlebar and both feet on the operator footrests during operation to maintain control of the vehicle.
- The passenger should always hold onto the operator, the seat strap or grab bar, if equipped, with both hands and keep both feet on the passenger footrests. Never carry a passenger unless he or she can firmly place both feet on the passenger footrests.
- Never ride under the influence of alcohol or other drugs.
- This vehicle is designed for on-road use only. It is not suitable for off-road use.

Protective apparel

The majority of fatalities from vehicle accidents are

the result of head injuries. The use of a safety helmet is the most critical factor in the prevention or reduction of head injuries.

- Always wear an approved helmet.
- Wear a face shield or goggles.

Wind in your unprotected eyes could contribute to an impairment of vision that could delay seeing a hazard.

- The use of a jacket, substantial shoes, trousers, gloves, etc., is effective in preventing or reducing abrasions or lacerations.
- Never wear loose-fitting clothes, otherwise they could catch on the control levers or wheels and cause injury or an accident.
- A passenger should also observe the above precautions.

Avoid Carbon Monoxide Poisoning.

All engine exhaust contains carbon-monoxide, a deadly gas. Breathing carbon monoxide can cause headaches, dizziness, drowsiness, nausea confusion, and eventually death.

Carbon Monoxide is a colorless, odorless, tasteless gas which may be present even if you do not see or smell any engine exhaust. Deadly levels of carbon monoxide can collect rapidly and you can quickly be overcome and unable to save yourself. Also, deadly levels of carbon monoxide can linger for hours or

days in enclosed or poorly ventilated areas. If you experience any symptoms of carbon monoxide poisoning, leave the area immediately, get fresh air, and seek medical treatment.

- Do not run engine indoors. Even if you try to ventilate engine exhaust with fans or open windows and doors, carbon monoxide can rapidly reach dangerous levels.
- Do not run engine in poorly ventilated or partially enclosed areas such as barns, garages.
- Do not run engine outdoors where engine exhaust can be drawn into a building through openings such as windows and doors.

Further safe-riding points

- Be sure to signal clearly when making turns.
- Braking can be extremely difficult on a wet road. Avoid hard braking, because the vehicle could slide. Apply the brakes slowly when stopping on a wet surface.
- Slow down as you approach a corner or turn. Once you have completed a turn, accelerate slowly.
- Be careful when passing parked cars. A driver might not see you and open a door in your path.
- Railroad crossings, streetcar rails, iron plates on road construction sites, and manhole covers become extremely slippery when wet. Slow down and cross them with caution. Keep the vehicle upright, other-

wise it could slide out .

- The brake pads could get wet when you wash the vehicle. After washing the vehicle, check the brakes before riding.
- Always wear a helmet, gloves, trousers (tapered around the cuff and ankle so they do not flap), and a bright colored jacket.
- Do not carry too much luggage on the vehicle. An overloaded vehicle is unstable. Use a strong cord to secure any luggage to the carrier (if equipped). A loose load will affect the stability of the vehicle and could divert your attention from the road.

WARNING

Always wear protective clothing that covers your legs, ankles, and feet. The engine or exhaust system become very hot during or after operation and can cause burns. Let the engine and exhaust system cool before touching it.

DESCRIPTION

Left view

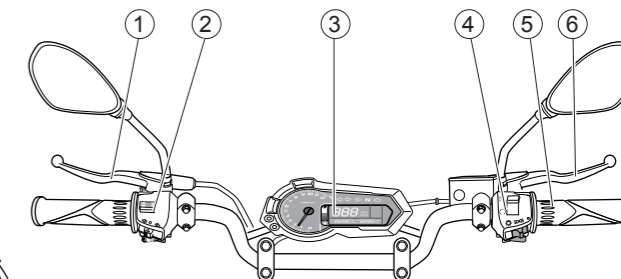
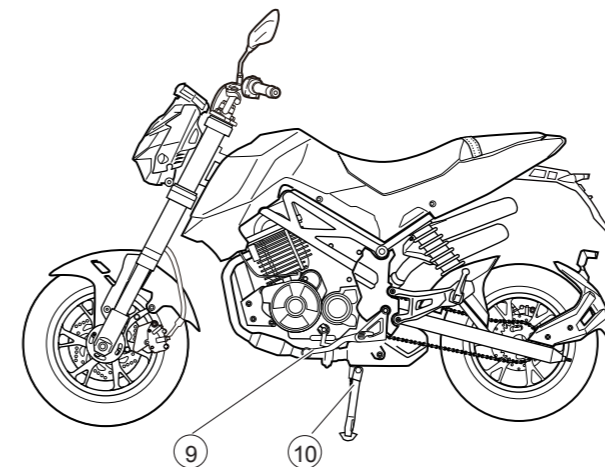

Right view

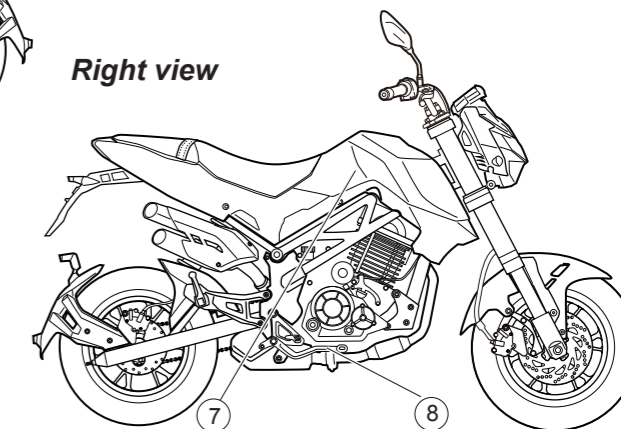

- | | |
|--------------------------|--------------------|
| ① Clutch lever | ⑦ Fuel tank |
| ② Left handlebar switch | ⑧ Rear brake pedal |
| ③ Meter | ⑨ Shift lever |
| ④ Right handlebar switch | ⑩ Side stand |
| ⑤ Throttle grip | |
| ⑥ Front brake lever | |

CONSUMER INFORMATION

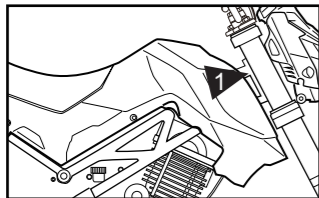

Vehicle identification number (VIN)

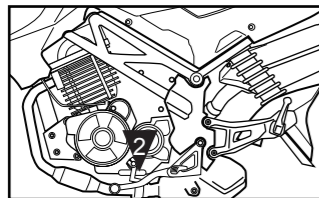

engine serial number

VIN No.
ENGINE No.

- The vehicle identification number ① is stamped on the right side steering head tube.
- The engine serial number ② is stamped on the lower left of the engine.

TIP

The vehicle identification number / the engine serial number are used to register the vehicle, they are also used to assist your dealer in terms of ordering parts or referring to special service information.

INSTRUMENT AND CONTROL FUNCTIONS

“⊗” (Off) position:
All the circuits are off.

“⊙” (On) position:
The circuits are on.

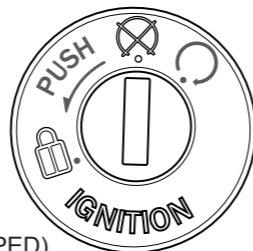

“P” (Parking): (IF EQUIPPED)
The taillight, license plate light and auxiliary lights are on. The hazard lights and turn signal lights can be turned on, but all other electrical systems are off. The key can be removed.

“🔒” (Steering Lock) (IF EQUIPPED)
Turn the steering handle to left, press the key to “🔒” position, the steering lock is locked. When it needs to open, insert the key and turn to “⊗” position, the steering lock is released;

NOTICE

Do not turn your key to lock the vehicle while driving which is not necessary and is also apt to cause accident.
Press the key in with proper force.

Meter & Indicator

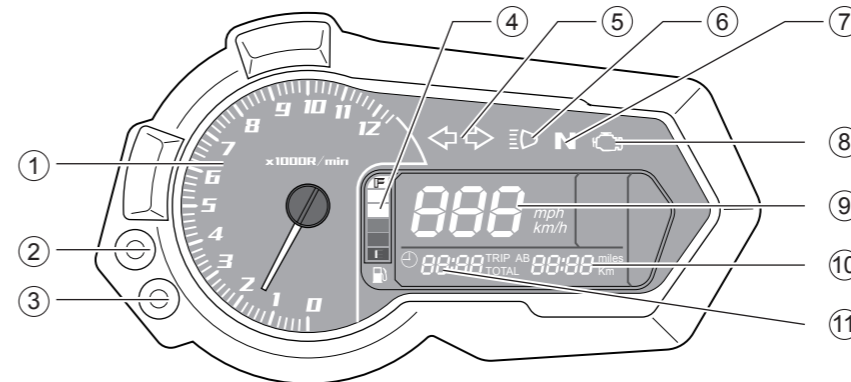

1. TACHOMETER

Tachometer indicates the revolution per minute of engine.

2. ADJUST BUTTON

Short press the button to switch between km/h and mph. Long press the button to reset the "Trip" mileage.

3. SELECT BUTTON

Short press the button to switch between trip and odometer functions on the meter. Press button "SELECT" for several seconds, there will appear the interface for time adjustment: "SELECT" for selection of digits of time display and "ADJUST" for adjustment of each value.

4. FUEL LEVEL INDICATOR:

It indicates the fuel level in the fuel tank.

5. TURNING INDICATOR

The indication lamps will flash with the turning signals.

6. HIGH BEAM INDICATOR LAMP

When the high beam lamp of the headlamp turns on, the high beam indicator lamp would be on.

7. NEUTRAL INDICATOR LAMP

When the transmission is in the neutral position, the indicator lamp would be on.

8. ENGINE CONTROL SYSTEM TROUBLE INDICATOR:

Return to authorized dealer if this indicator is activated during riding.

9. SPEEDOMETER

Speedometer shows the running speed, hours/kilometers.

10. ODOMETER & TRIP METER:

Relative mileage (TRIP): it records the mileage the vehicle covers in a period of time. Odometer (TOTAL): it records the total mileage the vehicle has covered in km.

11. CLOCK

Indicates the time.

HANDLEBAR

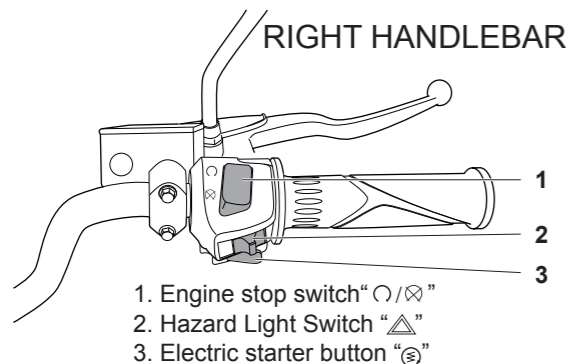
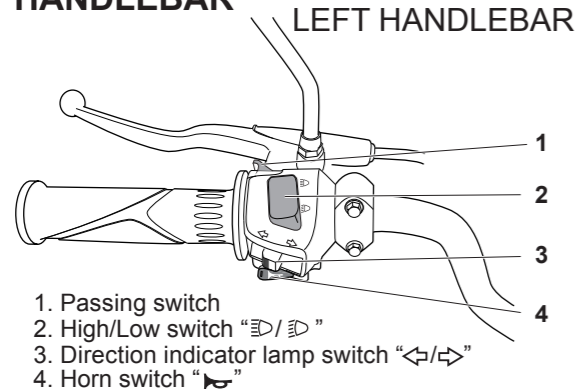

Dimmer switch

Turn the switch to "☰" position, the high beam of the headlamp will turn on and the indicator lamp on the meter will also turn on; turn the switch to "☷" position, the low beam of the headlamp will turn on.

Direction indicator lamp switch

Turn the switch to "↶" position, the left direction signal lamp flashes; turn the switch to "↷" position, the right direction signal lamp flashes. And the indicator lamps will turn on accordingly.



Turn on the direction signal lamps in time when changing lanes or turning a direction, turn off the lamps when turning is complete.

Passing switch (IF EQUIPPED)

When passing other vehicles, press this button so the high beams of the headlamp will flash to alarm the vehicles in front of you.

Horn button 📣

Press down on the button, to activate the horn.

Engine stop switch (IF EQUIPPED)

When the switch is on "⊙" position and the power is on, the engine runs. When the switch is on "⊗" position the power is off and the engine cannot be started.



Under normal conditions, this switch shall be on "Operate" (⊙) position. Use this switch during emergency situations, for example accident or key switch problems.

Electric starter button 🔌

Pull the clutch lever or put in Neutral gear and press the button to run the electric motor and start the engine.

Clutch lever switch (IF EQUIPPED)

When starting the engine or shifting, pull the clutch lever to cut off driving on the rear wheel.

Front brake lever

Pull the brake lever properly to use the front brake.

Throttle grip

Throttle grip is used to control the speed of engine. Twist the grip towards yourself to rev up or turn it in the opposite direction to slow down.

Light switch (IF EQUIPPED)

Turn switch to position of "☀️" to light up the front lamp; Turn to "☷☷" to light up meter lamp, city light and tail lamp.

Hazard Switch

Turn to "⚠️" and the four direction signal lamps will flash to warn for emergency situation; turn to "●" for daytime driving.

FUEL TANK

To open the fuel tank cap, insert the key and turn it clockwise and open the cover. To close the fuel tank, replace the cap and then press it down until the key can be removed. Remove the key when you hear the lock click.

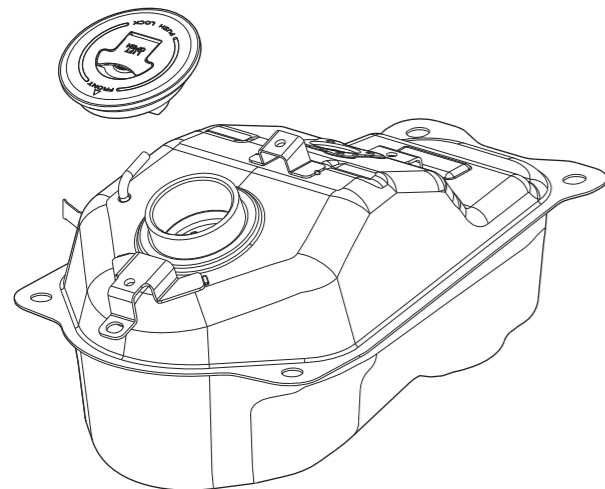

Recommended fuel:
REGULAR UNLEADED
GASOLINE ONLY
Fuel tank capacity:
7.2 L (1.9 Gallons)

⚠ WARNING

Do not over fill the fuel tank. Do not allow fuel to splash on the hot engine.
Please stop the engine and turn the ignition key to " ⏻ " (Off) position when you need to refuel.
Do not forget to lock the fuel tank cap after adding fuel in case of evaporation to the air, which is a waste of energy and would pollute the environment. Don't use fire when refueling.

REAR SHOCK ABSORBER

The rear shock absorber is equipped with a spring preload adjusting ring. The preload of the rear shock can be adjusted in compliance with the driver's weight and loading condition, driving method and road conditions. Adjust when vehicle it is stable on the main stand or side stand, turn the preload ring to the place required.

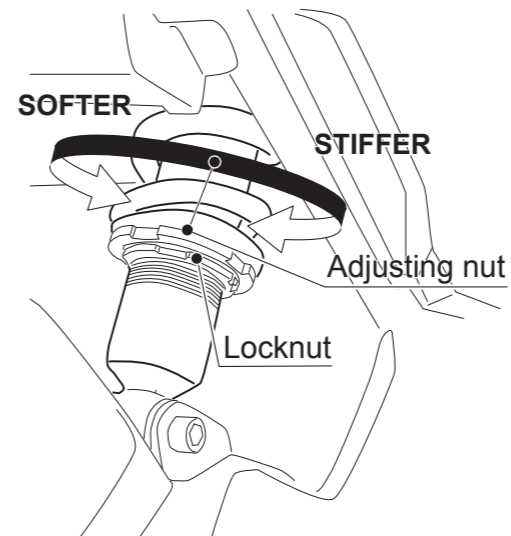

TORQUE VALUE
Upper fixing bolt: 37-44N.m
Lower fixing bolt: 22-29N.m
Adjustable

REAR BRAKE PEDAL

Step on the rear brake pedal to stop the rear wheel. The brake light will turn on while rear brake is in use.

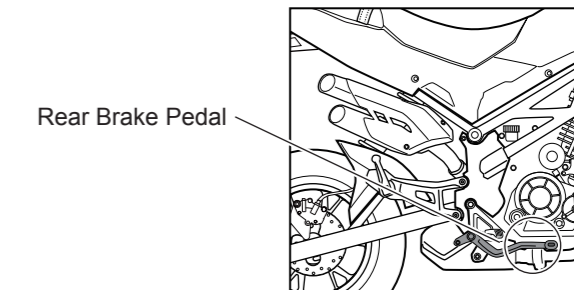

SHIFTER LEVER

Slow down the vehicle when shifting to lower gears. Revving up the engine slightly to shift gears is a smoother way to shift and avoid damaging gears.

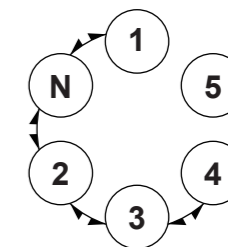

PRE-OPERATION CHECKS

Inspect your vehicle each time you use it to make sure the vehicle is in a safe operating condition. Always follow the inspection and maintenance procedures and schedules described in the Owner's Manual.

 **WARNING**

Failure to inspect or maintain the vehicle properly increases the possibility of an accident or equipment damage. Do not operate the vehicle if you find any problems. If a problem cannot be corrected by the procedures provided in this manual, have the vehicle inspected by a dealer.

Before using this vehicle, check the following points:

ITEM	CHECKS
Fuel	<ul style="list-style-type: none"> • Check fuel level in fuel tank. • Refuel if necessary. • Check fuel line for leakage
Engine oil	<ul style="list-style-type: none"> • Check oil level in the engine. • If necessary, add recommended oil to specified level. • Check vehicle for oil leakage.

ITEM	CHECKS
Disc brake (If equipped)	<ul style="list-style-type: none"> • Check operation. • If soft or spongy, have dealer bleed hydraulic system. • Check brake pads for wear. Replace if necessary. • Check fluid level in reservoir. If necessary, add recommended brake fluid to specified level. • Check hydraulic system for leakage.
Drum brake (If equipped)	<ul style="list-style-type: none"> • Check operation. • Check brake shoes for wear. Replace if necessary.
Throttle grip	<ul style="list-style-type: none"> • Make sure that operation is smooth. • Check cable free play. • If necessary, have a dealer adjust cable free play and lubricate cable and grip housing.
Clutch lever	<ul style="list-style-type: none"> • Make sure that operation is smooth. • Check cable free play. • If necessary, have a dealer adjust cable free play and lubricate cable.

OPERATION AND IMPORTANT RIDING TIPS

STARTING THE ENGINE

1. Turn the key to the "ON" position.
2. Put the transmission in neutral, or pull in the clutch lever.
3. Start the engine by pushing the start switch.

 **WARNING**

Do not start the engine indoors with bad ventilation or without ventilation. Do not leave a starting vehicle running when no one else is around.

 **NOTICE**

Do not rev the vehicle to high engine RPM's when it is not being ridden, this could cause the engine to overheat and damage it's internal parts.

ITEM	CHECKS
Wheels and tires	<ul style="list-style-type: none"> • Check for damage. • Check tire condition and tread depth. • Check air pressure.
Brake levers	<ul style="list-style-type: none"> • Make sure that operation is smooth.
Brake pedal	<ul style="list-style-type: none"> • Lubricate pivots if necessary.
Sidestand, Mainstand (If equipped)	<ul style="list-style-type: none"> • Lubricate pivots if necessary.
Instruments, lights, signals and switches	<ul style="list-style-type: none"> • Check operation.

Read the Owner's Manual carefully to become familiar with all of the controls. If there is a control or function you do not understand, ask your dealer.

 **WARNING**

Failure to familiarize yourself with the controls can lead to loss of control, which could cause an accident or injury.

ACCELERATION AND DECELERATION

The speed can be adjusted by opening and closing the throttle. To increase the speed, turn the throttle grip in direction (a). To reduce the speed, turn the throttle grip in direction (b).

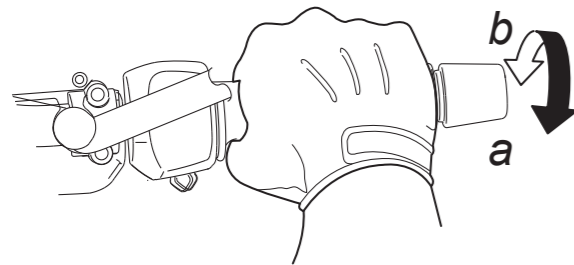

BRAKING

1. Close the throttle completely.
2. Apply both front and rear brakes simultaneously to keep the front end from diving while braking.

WARNING

It is dangerous to only use either the front brake or rear brake which may cause skidding or loss of control. Be careful and use the brakes properly when you drive on wet or winding roads.

ENGINE BREAK-IN

There is never a more important period in the life of your engine than the period between 0 and 600 miles. For this reason, you should read the following material carefully. Since the engine is brand new, do not put an excessive load on it for the first 600 miles. The various parts in the engine wear and fit to the correct operating clearances. During this period, avoid prolonged full-throttle operation or any condition that might result in engine overheating. The engine should not be over revved and all the gears shall not be over 80% of red zone engine rpm; don't operate the throttle under a fully open position; change the gears in time to keep the engine rpm in a

reasonable range. It is strongly suggested to use the vehicle very carefully during its running in period.

PARKING

1. The vehicle should be parked on a firm and flat surface.
2. Turn the power key to the position "  " to stop the engine.
3. Remove the ignition key from the switch after locking for security reasons.

PERIODIC MAINTENANCE AND ADJUSTMENT

Periodic inspection, adjustment, and lubrication will keep your vehicle in the safest and most efficient condition possible. Safety is an obligation of the

vehicle owner/operator. The most important points of vehicle inspection, adjustment, and lubrication are explained on the following pages. The intervals given in the periodic maintenance and lubrication chart should be considered as a general guide under normal riding conditions. However, depending on the weather, terrain, geographical location, and individual use, the maintenance intervals may need to be shortened.

WARNING

Failure to properly maintain the vehicle or performing maintenance activities incorrectly may increase your risk of injury or death during service or while using the vehicle. If you are not familiar with vehicle service, have a dealer perform the needed service.

NOTICE

- The annual checks must be performed every year, except if a mileage-based maintenance, is performed instead.
- The vehicle may have different accessory for different market and some parts may not exist for common chart.

PERIODIC MAINTENANCE CHART

ITEM	CHECKS	ODOMETER READING					
		600mi 1000km New	3000mi 4000km 3 months	5500mi 7000km 6 months	8000mi 10000km 9 months	10500mi 13000km 1 year	13000mi 16000km 15months
Fuel line	• Check fuel hoses for cracks or damage		●		●		
Spark plug	• Check condition. Clean and regap.		●		●		
	• Replace			●		●	
Valves	• Check/adjust valve clearance.	●		●		●	
Air filter element	• Inspect/cleaning/replace	●	●	●	●	●	●
Disc brake	• Check operation, fluid level and vehicle for fluid leakage.	●		●		●	
	• Inspect/replace brake pads.			●		●	
Drum brake	• Inspect/replace brake shoes.			●		●	
Wheels	• Check runout and damage.	●	●	●	●	●	●
Tires	• Check tread depth and damage.	●	●	●	●	●	●
	• Replace if necessary.	●	●	●	●	●	●
	• Check air pressure.	●	●	●	●	●	●
Chassis fasteners	• Make sure that all nuts, bolts and screws are properly tightened	●		●		●	
Front brake lever pivot shaft	• Lubricate with silicone grease.	●	●	●	●	●	●

ITEM	CHECKS	ODOMETER READING					
		600mi 1000km New	3000mi 4000km 3 months	5500mi 7000km 6 months	8000mi 10000km 9 months	10500mi 13000km 1 year	13000mi 16000km 15months
Rear brake lever pivot shaft	• Lubricate with silicone grease.	●	●	●	●	●	●
Side stand	• Check operation.	●	●	●	●	●	●
	• Lubricate.	●	●	●	●	●	●
Front fork	• Check operation and oil leakage.	●	●	●	●	●	●
Shock absorber	• Check operation and shock absorber for oil leakage.	●	●	●	●	●	●
Engine oil	• Change.	●	●	●	●	●	●
	• Check oil level and vehicle for oil leakage.	●	●	●	●	●	●
Engine oil strainer	• Clean.				●		
Front and rear brake switches	• Check operation.	●	●	●	●	●	●
Moving parts and cables	• Lubricate.	●	●	●	●	●	●
Throttle grip Housing and cable	• Check operation and free play.	●	●	●	●	●	●
	• Adjust the throttle cable free play if necessary.	●	●	●	●	●	●
Lights, signals and switches	• Check operation.	●	●	●	●	●	●
	• Adjust headlight beam.	●			●		

CHECKING THE SPARK PLUG

The spark plug is an important engine component, which should be checked periodically, preferably by a dealer. Since heat and deposits will cause any spark plug to slowly erode, it should be removed and checked in accordance with periodic maintenance. In addition, the condition of the spark plug can reveal the condition of the engine.

The porcelain insulator around the center electrode of the spark plug should be a medium-to-light tan (the ideal color when the vehicle is ridden normally). If the spark plug shows a distinctly different color, the engine could be operating improperly. Do not attempt to diagnose such problems yourself. Instead, have a dealer check the vehicle.

If the spark plug shows signs of electrode erosion and excessive carbon or other deposits, it should be replaced.

Before installing a new spark plug, the spark plug gap should be measured with a thickness gauge and, if necessary, adjusted to specification.

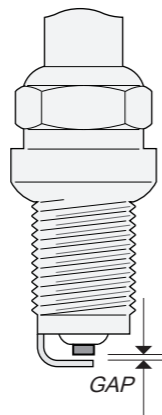

<p>Type <i>BOSCH A7RC</i> or <i>NGK CR7HSA</i> Gap <i>0.6 - 0.7mm</i></p>
--

Clean the surface of the spark plug gasket and its mating surface, and then wipe off any grime from the spark plug threads.

ENGINE OIL

The engine oil level should be checked before each ride. In addition, the oil must be changed at the intervals specified in the periodic maintenance and lubrication chart.

TO CHECK THE ENGINE OIL LEVEL

1. Start the engine, warm it up for several minutes, and then turn it off.

2. Wait a few minutes until the oil settles.
3. Hold the vehicle vertically. Inspect the engine oil level through the engine oil level window on the right side on the engine.
4. If the engine oil is below the minimum level mark, add sufficient oil of the recommended type to refill it to the correct level.

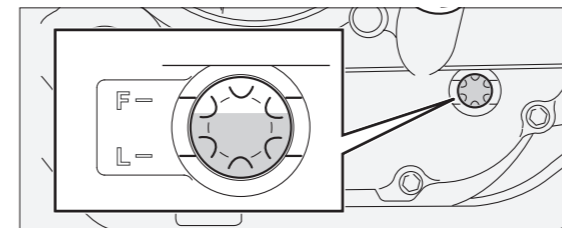

NOTICE

The engine oil should be between the minimum and maximum level marks.

TO CHANGE THE ENGINE OIL

1. Start the engine, warm it up for several minutes, and then turn it off.
2. Place an oil pan under the engine to collect the used oil.
3. Remove the engine oil filler cap and the engine oil drain bolt to drain the oil from the crankcase.
4. Install the washer and the engine oil drain bolt, and then tighten the drain bolt to the specified torque.
5. Refill with the specified amount of the recommended engine oil, and then install and tighten the oil filler cap.

<p>Type <i>API SH, SAE10W-40, JASO MA</i> Without Oil Cooler Capacity <i>0.9L ± 0.05L</i> Equipped Oil Cooler Capacity <i>1.1L ± 0.05L</i></p>

IDLE SPEED

Only use good quality fuel from a gasoline station to prevent the fuel from clogging the fuel pump strainer, or even the injector.

The engine is required to be at normal operating temperature for an accurate idle adjustment.

IDLE ADJUSTMENT

1. Keep the vehicle on a flat surface.
2. Start the engine and warm up the engine for several minutes.
3. Clip a digital Tachometer to the spark plug cable.
4. If the idle speed is not within the correct range, contact the nearest authorized dealer.

Idle speed: 1,500±100r/min

VALVE CLEARANCE

The valve clearance changes with use, resulting in improper air-fuel mixture and/or engine noise. To prevent this from occurring, the valve clearance must be adjusted by a dealer at the intervals specified in the periodic maintenance and lubrication chart.

The engine is required to be cold to perform an accurate valve clearance adjustment.

Valve clearance (Cold engine)

IN: 0.08 ~ 0.10mm EX: 0.08 ~ 0.10mm

AIR FILTER

The air filter element should be replaced and should be cleaned at the intervals specified in the periodic maintenance and lubrication chart.

REPLACING THE AIR FILTER ELEMENT

1. The air filter is located under the seat, remove the seat.
2. Park the vehicle on firm ground.
3. Remove the air filter case cover by removing the screws.
4. Pull the air filter element out.
5. Insert a new air filter element into the air filter case.
6. Install the air filter case cover by installing the screws.

A: Air Filter cover
B: Air Filter

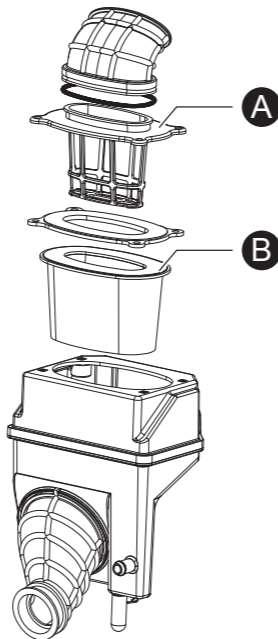

CHECKING THE THROTTLE CABLE FREE PLAY

The throttle cable free play should measure 3.0–5.0 mm at the throttle grip. Periodically check the throttle cable free play and, if necessary, have a dealer adjust it.

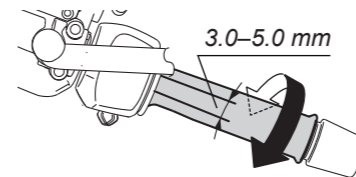

CHECKING THE CLUTCH FREE PLAY

The free play of clutch is measured from the free stroke of the lever. Adjust using the following method, if adjustment is necessary.

- (1) Loose the locknut.
- (2) Screw in or out the adjusting bolt to make the required free stroke.
- (3) Tighten locknut.

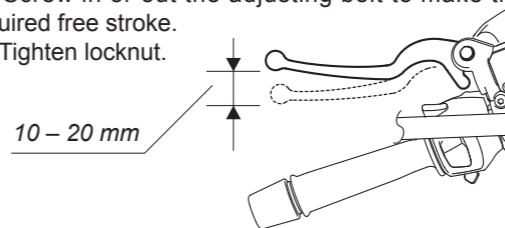

CHECKING THE FRONT BRAKE LEVER AND REAR BRAKE PEDAL FREE PLAY

The brake lever free play should measure 10-20 mm as shown. The brake pedal free play should measure 20-30 mm as shown. Periodically check the brake lever free play and, if necessary, have a dealer check the brake system.

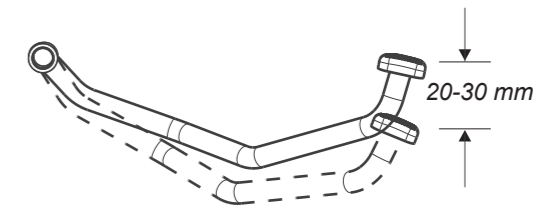
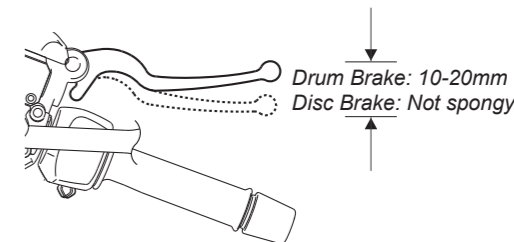

CHECK THE DRUM BRAKE LIMIT (IF EQUIPPED)

Adjustment Nut

- Turn the adjustment nut on brake arm of rear wheel to adjust the free play of rear brake.
- Press the rear brake pedal after adjusting until there is effective brake feeling.

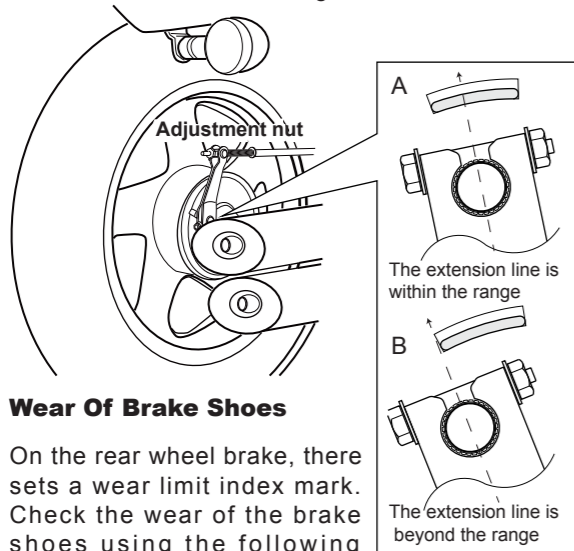

Wear Of Brake Shoes

On the rear wheel brake, there sets a wear limit index mark. Check the wear of the brake shoes using the following method:

1. Check if the brake system is properly adjusted.
2. Check if braking function is normal, and if the limit index extension line is within the allowable range, as shown in Figure A.
3. If the limit index extension line is beyond the allowable range, as shown in Figure B, please go to your local distributor for replacement of components in the braking system to ensure driving safety.

CHECKING THE BRAKE PADS

The front and rear brake pads must be checked for wear at the intervals specified in the periodic maintenance and lubrication chart.

Each brake pad is provided with wear indicator grooves, which allow you to check the brake pad wear without having to disassemble the brake. To check the brake pad wear, check the wear indicator grooves. If a brake pad has worn to the point that the wear indicator grooves have mostly disappeared, have a dealer replace the brake pads as a set.

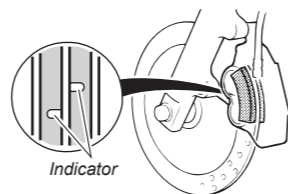

WARNING

In case of drinking the brake fluid by mistake or contacting with eyes or skin, wash with a large amount of water, and seek medical advice immediately if a serious condition.

Don't forget to check the fluid level in the brake fluid reservoir. Add appropriate brake fluid if necessary.

BRAKE FLUID

The brake system is tuned before delivery. Contact your dealer if any problems occur.

Recommended brake fluid
DOT 4

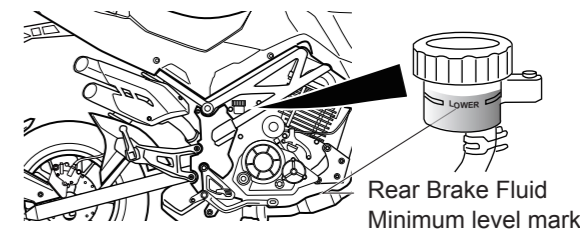
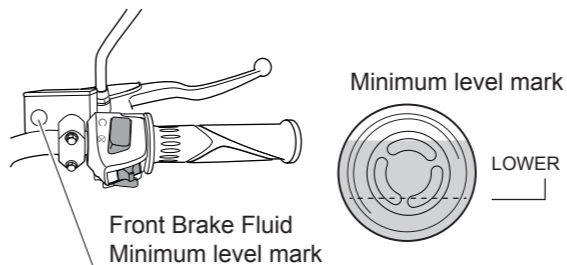

CHECKING THE BATTERY

Your battery is prefilled and activated from your dealer. There is no need to add electrolyte, your battery is sealed and should not be opened for any reason. Have a dealer charge the battery as soon as possible if it seems to have discharged. Keep in mind that the battery tends to discharge more quickly if the vehicle is equipped with optional electrical accessories.

WARNING

The battery will produce explosive gas, beware of using open flames or sparks near the battery. Your battery is sealed and should not be opened at any time. The battery contains sulfuric acid (electrolyte) which can cause eye damage or skin burns.

12V6Ah (YTX7A-BS)
MF (Maintenance Free) Battery

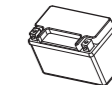

REPLACING THE FUSES AND BULBS

If a fuse or bulb for the individual circuits is blown, replace it as follows.

1. Turn the key to "OFF" and turn off the electrical circuit in question.
2. Remove the blown fuse or bulb, and then install a new fuse or bulb of the specified type.

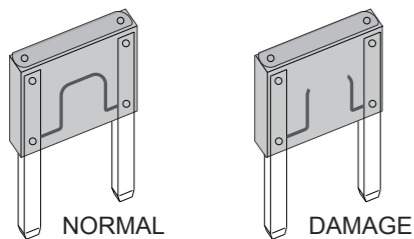

Main Fuse	20A
EFI System Fuse	15A

WARNING

Do not use a fuse or bulb of a higher amperage rating than recommended to avoid causing extensive damage to the electrical system and possibly a fire or other problems.

Meter Light	12V 2W
Horn	12V 3A
Headlight bulb	LED
Turn light	LED
City light	LED
Taillight bulb	LED

TIRES

Inflation pressure and tire tread should be regularly checked. In order to ensure maximum safety and longer service life, inflation pressure requires more frequent routine check.

Tire Pressure

Insufficient tire pressure will not only accelerate wear, but also will have a bad impact on driving stability such as making turning difficult. However, too much pressure will reduce the contact area between the tire and ground, thus causing slipping or even getting out of control. Tire pressure should be kept in

the standard range. Adjust the tire pressure under a "cold" condition.

TIRE INFORMATION	
COLD TIRE PRESSURE	
[FRONT] 33psi (2.25kgf/cm ²)	[REAR] 33psi (2.25kgf/cm ²)

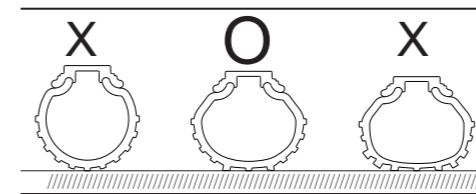

STORAGE

Short-term

Always store your vehicle in a cool, dry place and, if necessary, protect it against dust with a porous cover.

Long-term

Before storing your vehicle for several months:

1. Change the engine oil.

2. Lubricate the drive chain.
 3. Drain fuel from the fuel tank. Install the fuel tank cap again.
 4. Remove the spark plug and add one teaspoon of (15~20cm³) clean engine oil to the cylinder, then reinstall the spark plug again.
 5. Remove the battery. Keep the battery in a cool place which can avoid freezing and direct sunlight. Charge the battery or examine the electrolyte level (if equipped with lead-acid battery) often.
 6. Clean and dry the vehicle. Wax the surface of the paint.
 7. Inflate tires to the required pressure. Put the vehicle on a stand to keep the tires off the ground.
 8. Cover the vehicle (no plastic or coating material) and keep it in a place of consistent temperature and low humidity. Do not keep your vehicle under direct sunlight.
- To use the vehicle after storage:
1. Remove the cover and clean the vehicle. Change the engine oil if you stored your vehicle for more than four months.
 2. Examine the electrolyte level and charge as needed. Install the battery.
 3. Wash away the anti-rust agent in fuel tank (if applied), and add fresh gasoline into the fuel tank.

SPECIFICATIONS

Size and Weight

Length 72.44 in.
 Width 30.51 in.
 Height 40.35 in.
 Wheelbase 57.48 in.
 Dry Weight 256 lbs.

Engine

Type Single-cylinder, Four-stroke, Air-cooled
 Model 154FMI-7A
 Bore x Stroke Ø54x58.8mm
 Displacement 134.7cc
 Ignition System Type TLI
 Compression Ratio 9.8:1
 Maximum Power 8.4kW@8500r/min

Maximum Torque 10N.m@7000r/min

Tire

Front tire 120/70-12
 Rear tire 130/70-12

Fuel

Fuel Tank 7.2 L
 Fuel Type Regular unleaded gasoline only

Brake

Front Brake Type Disc Brake
 Rear Brake Type Disc Brake

NOTES

.....

.....

.....

.....

.....

.....

.....

.....

.....

.....

.....

.....

.....

.....

EMISSION CONTROL SYSTEM

YOUR WARRANTY RIGHTS AND OBLIGATIONS

The California Air Resources Board, the U.S. Environmental Protection Agency, and SSR MOTORSPORTS. (hereinafter "SSR") are pleased to explain the Emission Related Components warranty on your 2019 Highway Motorcycle. New highway motor vehicles must be designed, built and equipped to meet U.S. EPA Federal and California anti-smog standards. SSR must warrant the Emission Related Components on your vehicle for 12,000mi or for 5 years, whichever comes first, provided that there has been no abuse, neglect or improper maintenance of your vehicle.

Your emission control system may include parts such as the carburetor or fuel injection system, the ignition system, catalytic converter and engine computer, if it is equipped. Also included may be hoses, belts, connectors and other emission-related assemblies.

Where a warrantable condition exists, SSR will repair your vehicle at no cost to you, for parts and labor.

If an emission-related part on your vehicle is defective, the part will be repaired or replaced by SSR. This is your emission control system DEFECTS WARRANTY.

OWNER'S WARRANTY RESPONSIBILITIES

As the vehicle owner, you are responsible for the performance of the required maintenance listed in your owner's manual. SSR recommends that you retain all receipts covering maintenance on your vehicle, but SSR cannot deny warranty solely for the lack of receipts or for your failure to ensure the performance of all scheduled maintenance.

You are responsible for presenting your vehicle to the SSR' dealer as soon as a problem exists. The warranty repairs should be completed in a reasonable amount of time, not to exceed 30 days.

As the vehicle owner, you should be aware that SSR may deny your warranty coverage if your vehicle or a part has failed due to abuse, neglect, improper maintenance or unapproved modifications.

If you use your vehicle in any type of competitive event, this warranty is immediately and completely void.

If you have any questions regarding your warranty rights and responsibilities, you should contact SSR MOTORSPORTS, 12825 Alondra Blvd., Norwalk, CA 90650 TEL: 562-926-2888 or (for California registered highway vehicles only) the California Air Resources Board at 9528 Telstar Avenue, El Monte, CA 91731-8001. SSR warrants that each new 2019 and later SSR highway motorcycle:

- A: is designed, built and equipped so as to conform at the time of initial retail purchase with all applicable regulations of the United States Environmental Protection Agency, and the California Air Resources Board;
- and
- B: is free from defects in material and workmanship which cause such vehicle to fail to conform with applicable regulations of the United States Environmental Protection Agency or the California Air Resources Board for the periods specified above.

I. COVERAGE

Warranty defects shall be remedied during customary business hours at any authorized SSR' dealer located within the United States of America in compliance with the Clean Air Act and applicable regulations of the United States Environmental Protection Agency and the California Air Resources Board. Any part or parts replaced under this warranty shall become the property of SSR.

II. LIMITATIONS

- This Emission Control System Warranty shall not cover any of the following:
- A. Repair or replacement as a result of
- (1) accident,
 - (2) misuse,
 - (3) repairs improperly performed or replacements improperly installed,
 - (4) use of replacement parts or accessories not conforming to SSR' specifications which adversely affect performance and/or
 - (5) use in competitive racing or related events.

B. Inspections, replacement of parts and other services and adjustments required for required maintenance.

C. Any vehicle equipped with an odometer or hour meter on which the odometer mileage or hour meter reading has been changed so that actual mileage cannot be readily determined.

III. LIMITED LIABILITY

A. The liability of SSR under this emission control system warranty is limited solely to the remedying of defects in material or workmanship by an authorized SSR' dealer at its place of business during customary business hours. This warranty does not cover inconvenience or loss of use of the vehicle or transportation of the vehicle to or from the SSR' dealer. SSR shall not be liable for any other expenses, loss or damage, whether direct, incidental, consequential or exemplary arising in connection with the sale or use of or inability to use the vehicle for any purpose. Some states do not allow the exclusion or limitation of any incidental or consequential damages, so the above limitations may not apply to you.

B. No express emission control system warranty is given by us except as specifically set forth herein. Any emission control system warranty implied by law, including any warranty of merchantability or fitness for particular purpose, is limited to the express emission control system warranty terms stated in this warranty.

The foregoing statements of warranty are exclusive and in line of all other remedies. Some states do not allow limitations on how long an implied warranty lasts so the above limitations may not apply to you.

C. No dealer is authorized to modify this SSR Limited Emission Control System Warranty.

IV. LEGAL RIGHTS

This warranty gives you specific legal rights, and you may also have other rights which vary from state to state.

V. THIS EMISSION CONTROL SYSTEM WARRANTY IS IN ADDITION TO THE STANDARD LIMITED WARRANTY FOR ALL VEHICLES.

VI. ADDITIONAL INFORMATION

Any replacement part that is equivalent in performance and durability may be used in the performance of any maintenance or repairs. However, SSR is not liable for these parts. The owner is responsible for the performance of all required maintenance. Such maintenance may be performed at a service establishment or by a qualified individual. The warranty period begins on the date the motorcycle is delivered to an ultimate purchaser.